

DN80 TO DN100
MAINLINE ONLY

The information on this sheet is Private and Confidential and is the property of Crane Process Flow Technologies Limited and must not be published directly or indirectly in any manner whatsoever without the written permission of the Company and must not be used in any way detrimental to their interests.
© Crane Process Flow Technologies

CRANE Process Flow Technologies
A Crane Co. Company

Saunders
The Science Inside

Title
SCHEDULE OF LEADING DIMENSIONS FOR DN80 WEIR
'T' BODY WITH ISO 1127 S1 BUTT WELD ENDS

Drawn JRD	Date 14.10.11	UNCONTROLLED IN HARD COPY FORMAT	
Checked RND	Date 23.03.12	Drawing No. WEB-080	
First Angle Projection Method E		DO NOT SCALE	Issue. 2

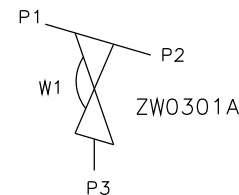

ORIENTATION AS
PER P&ID DIAGRAM FOR
OPTIMUM DRAINABILITY.

MAINLINE SIZE	A	B	C	D	ϕE	ϕF	G	BODY WEIGHT
mm	mm	mm	mm	mm	mm	mm	mm	Kgs
DN80	50.8	50.8	49.9	68.5	88.9	83.7	46.5	18.5
DN100	101.6	50.8	62.6	82.0	114.3	109.1	46.5	25.8

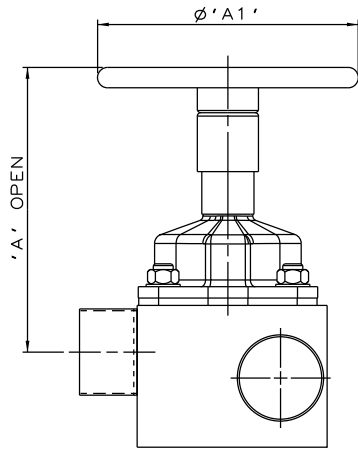

SS NON SEALED
BONNET ASSEMBLY

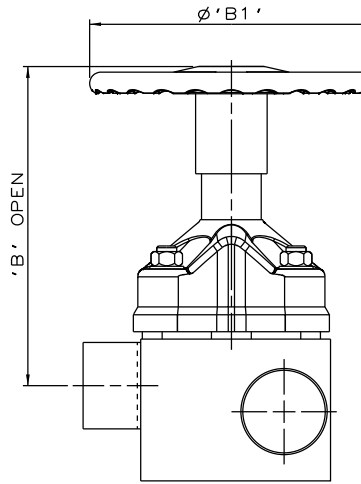

PES BONNET
ASSEMBLY

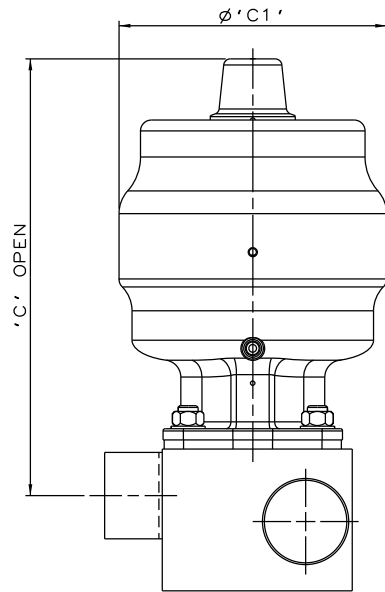

*S360 ACTUATOR

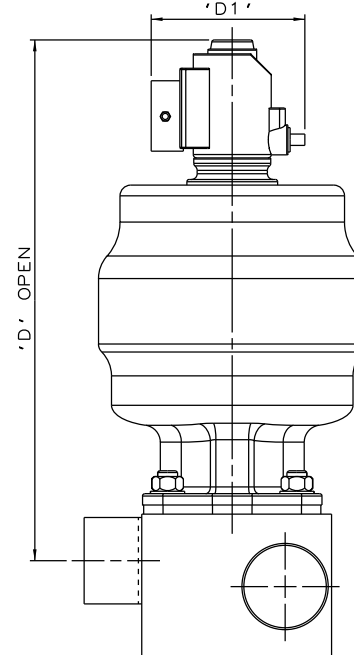

*S360 ACTUATOR
WITH I-VUE SENSOR

*DIMENSIONS SHOW MAXIMUM ENVELOPE FOR ALL MODES

BRANCH SIZE		A		A1		B		B1		C		C1		D		D1	
mm	inch	mm	inch	mm	inch	mm	inch	mm	inch	mm	inch	mm	inch	mm	inch	mm	inch
DN80	3.00	257.5	10.14	230.0	9.06	297.5	11.71	250.0	9.84	405.5	15.96	236.0	9.29	478.5	18.84	136.0	5.33

The information on this sheet is Private and Confidential and is the property of Crane Process Flow Technologies Limited and must not be published directly or indirectly in any manner whatsoever without the written permission of the Company and must not be used in any way detrimental to their interests.
© Crane Process Flow Technologies

CRANE Process Flow Technologies
A Crane Co. Company

Saunders
The Science Inside

Title
SCHEDULE OF LEADING DIMENSIONS FOR DN80/3.00
WEIR 'T' BODY WITH BUTT WELD ISO 1127 S1 ENDS.
FITTED WITH TOPWORKS OPTIONS

Drawn RI	Date 09.05.17	UNCONTROLLED IN HARD COPY FORMAT	
Checked RND	Date 09.05.17		
First Angle Projection Method E	DO NOT SCALE	Drawing No. WEB-080-ASSY	Issue. 1